

CCDE Practical ISP Scenario

LMNOP LLC

By: Nicholas Russo

Date Last Modified: 21 October 2016

Document 1: Company background

LMNOP LLC (simply LMNOP) is a small tier-3 ISP in Western Europe which has grown organically through the years. Founded in 1998 by two French nationals, the company currently offers internet access and 78 channels of IPTV. These TV services include pay-per view, live news reporting, and movie/sitcom replays. LMNOP does not have any IPTV sources locally within its domain but rather received these point-to-point feeds from some of its upstream peers. Most of LMNOP's customers are residential customers who connect to the ISP using traditional wireless services such as cable and DSL. The company has a strong IP networking team but has not refreshed its DSLAMs since it was founded given cost-cutting measures. DSL service currently provides the lion's share of revenue for the company with cable as a distant second. PON is being rolled out within the next 6 months for business-class/SOHO customers, as well as some SMBs.

The company currently employs 44 individuals within France and Germany. Most employees work at one of the two NOCs throughout Europe while some employees work remotely, such as executives and the sales force. Each POP has its own NOC but both NOCs have full administrative privileges to all devices in the networks; the POPs have no real autonomy and exist mostly for network extension/access, not fault tolerance. One POP is located in Paris, France with the other in Manheim, Germany. LMNOP has shown interest in competing with larger ISP by scheduling an introduction of VPN services for business customers as well. They believe this will increase the overall headcount in terms of support; this increase in headcount is a concern for LMNOP.

LMNOP's organic growth is beginning to slow as the number of available IPv4 addresses reduces. As a carrier providing only Internet services today, existing LSN solutions have worked well for years but are towards the end of their usefulness. The operational cost of maintaining dedicated storage appliances for HSL has proven to be highly unprofitable. European regulators require LSN logging to be stored for a minimum of 18 months and LMNOP has been unsuccessful in their litigation for adjusting these laws to create escape clauses for smaller ISPs. Note that all routers are chassis-based with stateful route-processor synchronization for fast control-plane failure.

The company is also struggling to deliver high-quality IPTV to its customers, which is a frequently-consumed service offering. Customers often complain that the video is choppy and sometimes stops completely for a few seconds. LMNOP has traffic prioritization configured in the core and POP networks but is still unable to determine why this is occurring. Upper management is pushing for rapid resolution to this issue.

LMNOP has one main data center connected to their Internet edge routers. At present, the DC is only used for CGN logging which is enormous in quantity. Several other DCs are scattered throughout Europe which are "cold" and are used for storing all the CGN logs over time, since the "hot" DC is mostly heavy on compute resources, not storage. Logs are transferred via ground transportation from hot to cold DCs every 3 weeks to make space for new logs in the hot DC.

All routers are in a single AS running IS-IS L2 with a full mesh of IPv4 iBGP peers. This design has proven very simple and offers optimal traffic forwarding in the network. These are both important considerations for LMNOP but the full mesh is hindering the organic growth of the company.

Document 2: Network Diagram

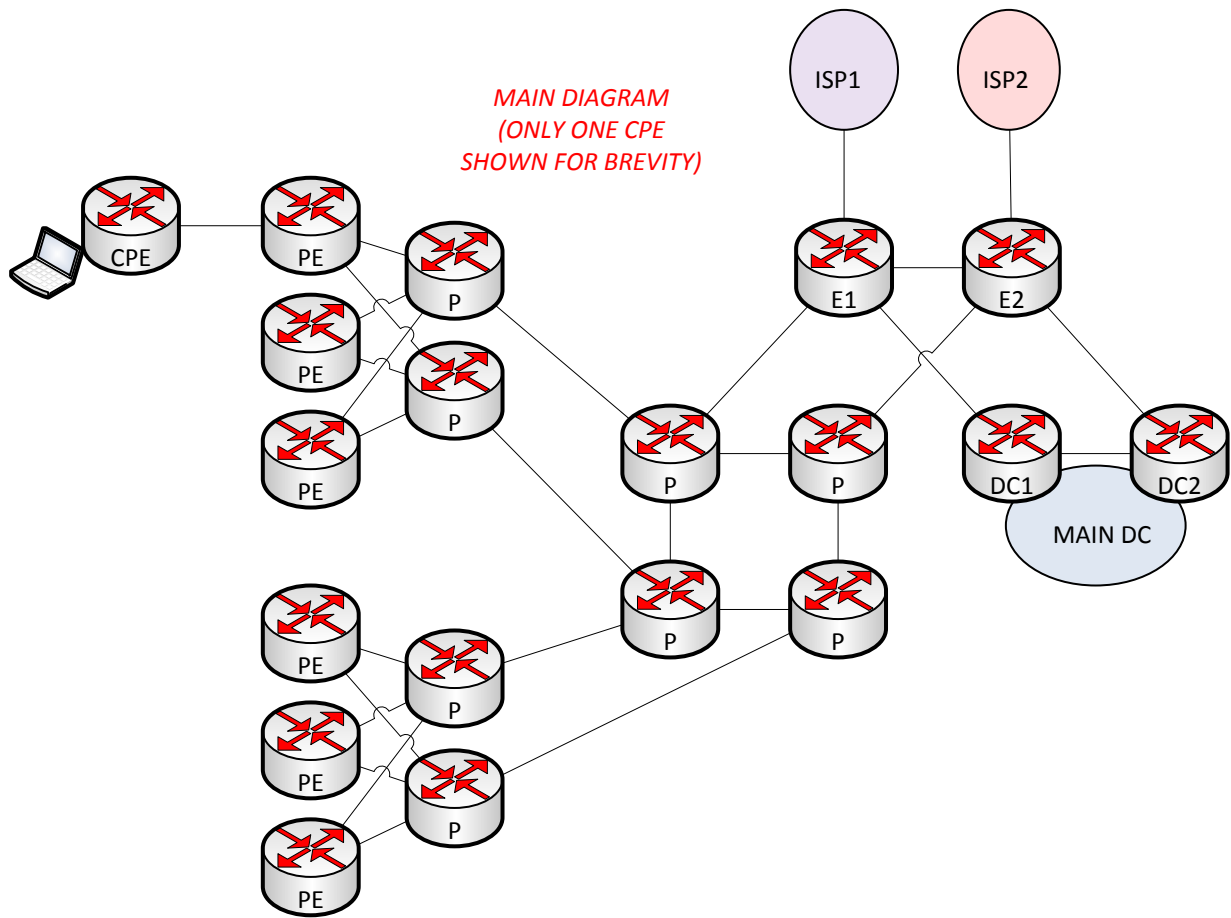

To: Designer

From: Nicky "Buffers" Johnson

Subject: Internet BGP migration and MPLS VPN service rollout

Hey, we are looking to migrate away from our full iBGP mesh so that we can grow the network in a way which requires fewer changes whenever new routers are added. Netflow is used in the core to collect customer flow statistics (we are usually careful to avoid privacy/regulatory lawsuits!) so those routers, despite being pretty beefy in terms of DRAM, are retaining quite a bit of flow data. Router DRAM remains at a premium, I just checked with our reseller, so please don't tell us we need to add more to support things like flow collection. Our Netflow samplers are set to 10% with deterministic sampling to help us conserve this critical resource. From a control-plane perspective, we introduce some Internet prefix aggregation into our network to save on memory on the core routers. We do retain the entire IPv4/v6 internet tables at the edge to provide optimal egress routing. On another note, the individual POPs don't really need to be autonomous since we are providing end-to-end internet and VPN service. Oh wait, I guess this is the first you are hearing about VPN ... yea, we need that too. This new core business offering aims to provide private network service for business customers in a manner that is maximally isolated from the Internet. The idea is that we, as a carrier, will be highly transparent by just carrying customer routing between PE-CE and not modifying it much. And everything needs to be "V6-ready" as our management says, whatever that means. Ideally, we want to ensure our existing customers using existing service offerings are less affected by the introduction of new services given that Internet services are revenue-generating while VPN is too new to be profitable. PS: my enter key is broken so sorry for the wall of text, can't figure out how to do paragraphs without the enter key. Tech support is going to come up later after they finish some access switch hardware upgrades.

1. Given the requirements, how would you separate or combine the BGP AFIs that need to be supported while migrating away from iBGP full mesh? Choose one.
 - a. Separate RRs for all AFIs (separate pair for IPv4, IPv6, VPNv4, VPNv6)
 - b. Single pair of RRs for all AFIs (IPv4, IPv6, VPNv4, VPNv6)
 - c. Combine IPv4/IPv6 on one pair and VPNv4/v6 on another pair
 - d. Combine IPv4/VPNv4 on one pair and IPv6/VPNv6 on another pair
 - e. Different confederation sub AS for IPv4/v6 vs. VPNv4/v6 services
 - f. Different confederation sub AS for IPv4/VPNv4 vs. IPv6/VPNv6 services
 - g. Just enable MPLS in the core

2. Why did you select this combination? Choose one.
- a. Memory conservation
 - b. Reduced fate-sharing**
 - c. Optimal traffic forwarding
 - d. Increased security
 - e. CAPEX reduction

To: Designer

From: Nicky "Buffers" Johnson

Subject: ooops!

Good afternoon,

I forgot to send you this. Pretty rotten for me to ask you to start making network design decisions with very limited information. These are the tentative locations for the RRs. We will be combining IPv4/v6 and VPNv4/v6 as we feel this gives us a balance of resilience and cost savings. The intent is to peer all routers with both RRs so we can avoid route reflection issues. Got my enter key fixed at least ☺ ☺ ☺

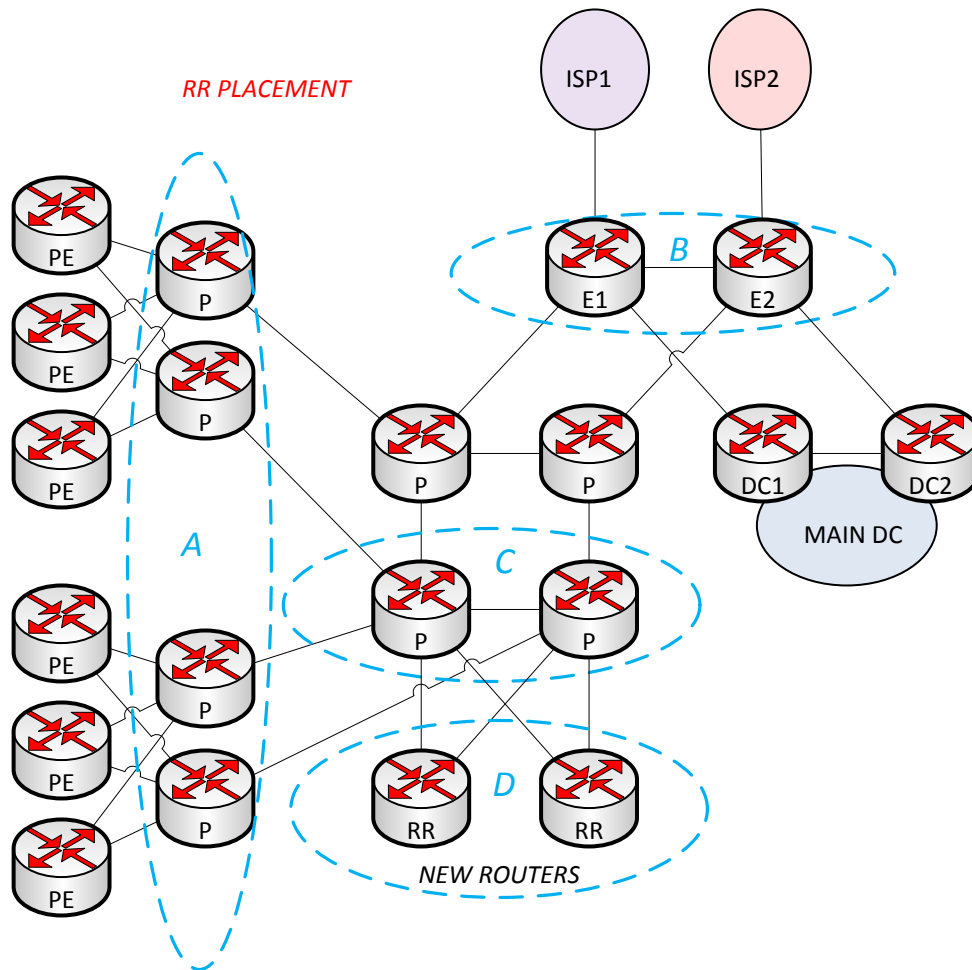

3. Given the requirements, where would you place the IPv4/v6 BGP route reflectors? Choose one.
- a. Location A
 - b. Location B**
 - c. Location C
 - d. Location D
 - e. I would use confederations

4. Why would you choose this position? Choose one.

- a. Memory conservation
- b. Reduced fate-sharing
- c. Optimal traffic forwarding
- d. Increased security
- e. CAPEX reduction

5. Given the requirements, where would you place the VPNv4/v6 route reflectors? Choose one.
- a. Location A
 - b. Location B
 - c. Location C
 - d. Location D**
 - e. I would use confederations

6. Why would you choose this position? Choose one.
- a. Memory conservation
 - b. Reduced fate-sharing
 - c. Optimal traffic forwarding
 - d. Increased security
 - e. CAPEX reduction

To: Designer

From: Nicky "Buffers" Johnson

Subject: RR decision

Hey there,

Thanks for your help. We've decided to put the IP-based RRs at the internet edge since they already need the full Internet table (and multiple copies of it for resilience). This strategy could also allow us to tunnel Internet service across our core in the future, though we aren't quite ready for this. Maybe later. Good call on adding some out-of-band VPN RRs in the network; spending a little bit of money to keep those out of the transit path might help protect them from Internet-based DDoS attacks that sneak through our CGNs at the edge. As I said earlier, route reflection shouldn't be a big problem for either AFI. We will be peering all routers in the topology to the IP RRs so they can learn the coarsely aggregated routes created by the edge routers ... we typically don't run the full table within our own AS due to DRAM concerns, as you are probably sick of hearing by now. We can't afford dedicated PEs for VPN access so we will reuse the internet PEs for this purpose along with different customer-facing VPN ports to avoid route-leaking. We intend to peer all PEs in both POPs to both VPN RRs for resilience (pretty basic stuff, I think). Attached is a diagram.

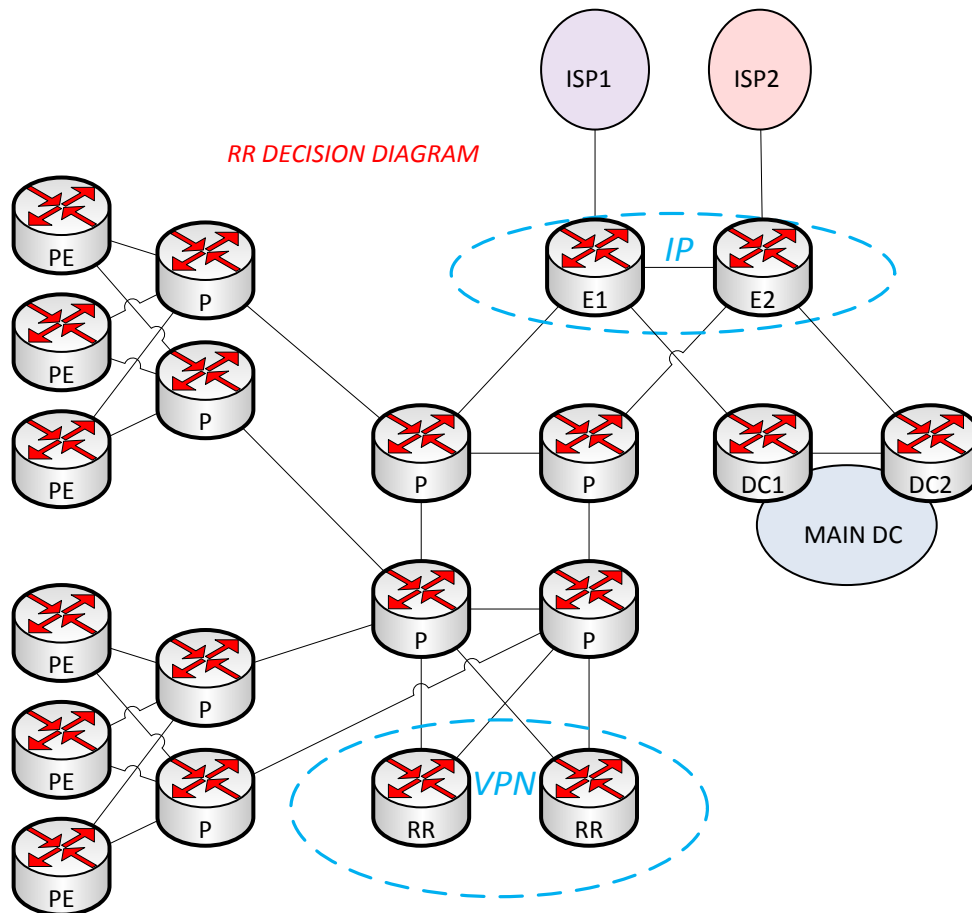

7. Given the requirements, complete the diagram below to implement your BGP RR solution.
Check all that apply.

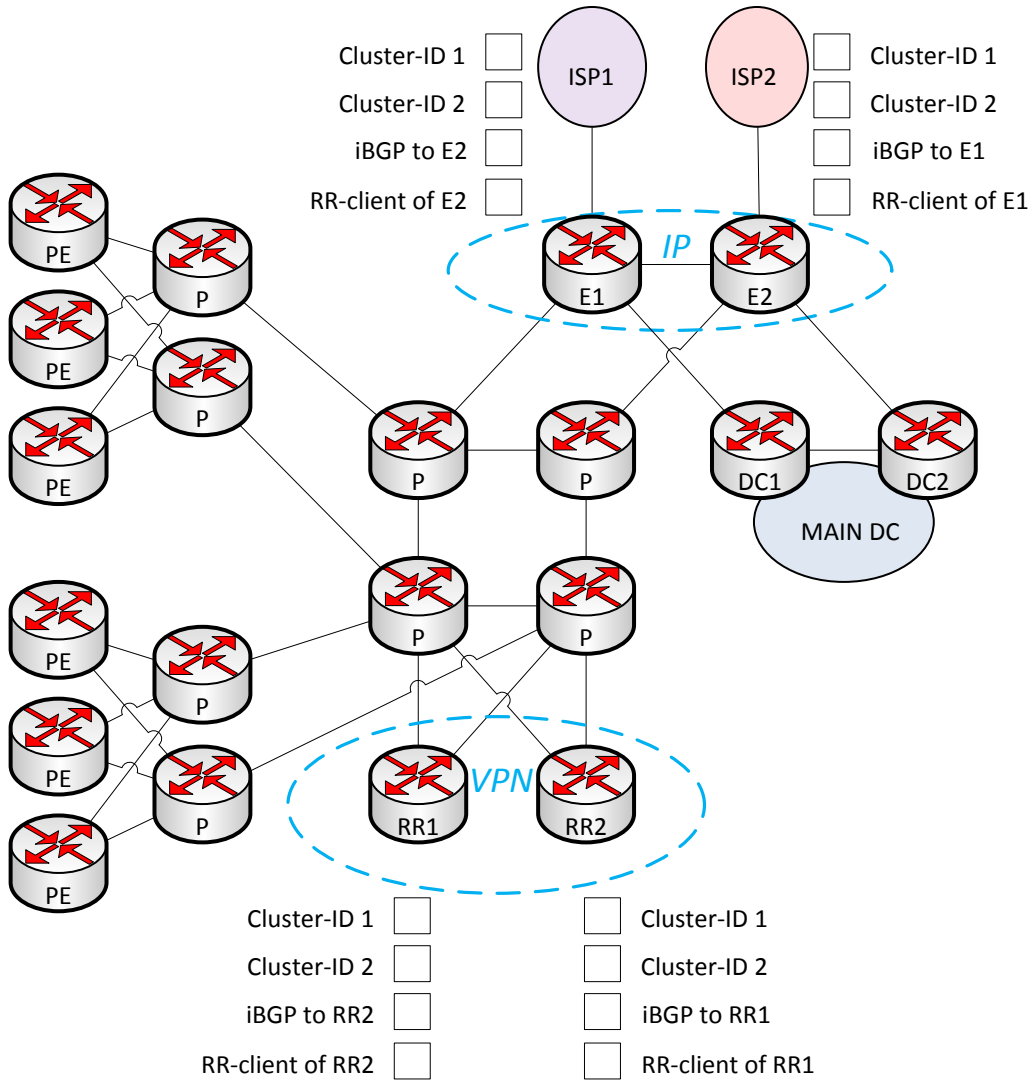

Correct answer:
 -No iBGP between VPN RRs
 -iBGP w/ same cluster between IP RRs
 (both ID 1 or both ID 2 are valid)

- | | | | | | |
|-----------------|-------------------------------------|------|-----------------|-------------------------------------|------|
| Cluster-ID 1 | <input checked="" type="checkbox"/> | ISP1 | Cluster-ID 1 | <input checked="" type="checkbox"/> | ISP2 |
| Cluster-ID 2 | <input type="checkbox"/> | | Cluster-ID 2 | <input type="checkbox"/> | |
| iBGP to E2 | <input checked="" type="checkbox"/> | | iBGP to E1 | <input checked="" type="checkbox"/> | |
| RR-client of E2 | <input type="checkbox"/> | | RR-client of E1 | <input type="checkbox"/> | |

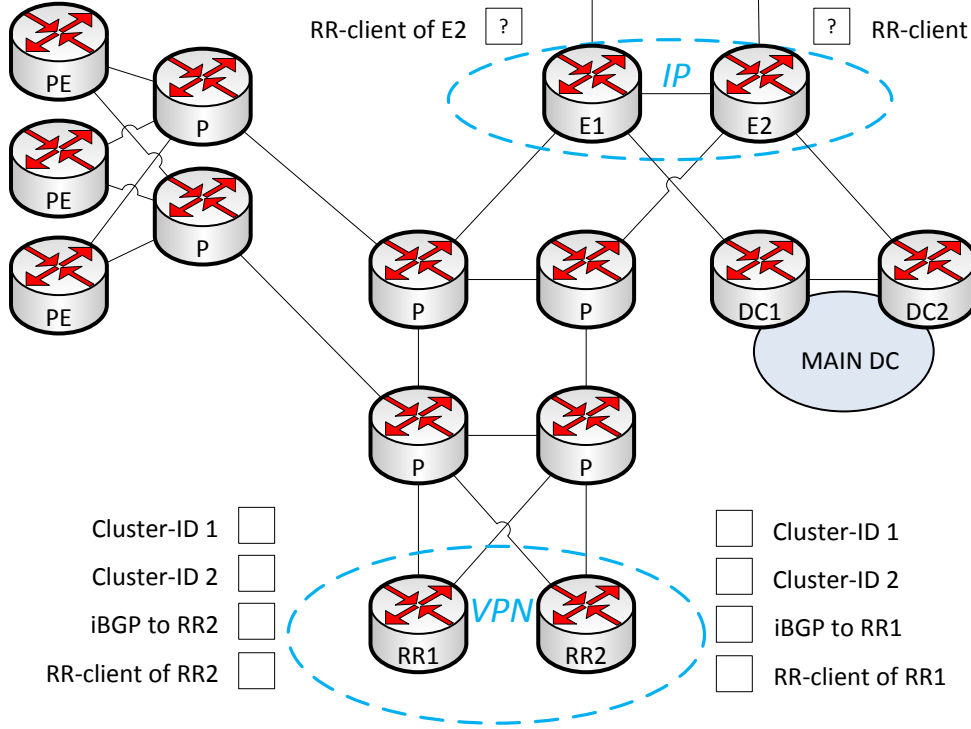

To: Designer

From: Nicky "Buffers" Johnson

Subject: Problems

Designer!

We have some pretty serious issues after implementing some of your ideas, although I'll admit we did deviate quite a bit. Obviously, we enabled MPLS (we used LDP everywhere) to support our VPN services, so we didn't feel like we needed to ask you how to do it. We just needed to allocate labels for all router loopbacks in the network and VPN services worked great right away! We wasted some time trying to enable LDPv6, which isn't supported on the P routers yet, but realized it was unnecessary for VPNv6. Whatever, I still got paid for the time at work.

We currently have IPv4 and IPv6 BGP all through the core and have serious memory and CPU over-commitment issues due to retaining tons of routes and running bestpath non-stop (we decided to let the full v4/v6 tables into the core for more granular traffic-engineering). Yes, I know I told you 100 times that we used aggregation at the edge; someone did some math on the DRAM requirement and forgot a decimal point. The CPUs of the routers were never particularly impressive, though, as this was a CAPEX reduction technique 4 years ago when we refreshed them. We recently decided to stop running BGP IPv6 on all routers in the core due to memory concerns since we are already carrying a good chunk of the IPv4 table there. We haven't implemented this yet, I just left a meeting with upper-management where this decision was made. We think we can originate some coarse aggregates into IGP (a few hundred) for IPv6 at the edge routers to attract egress traffic and save some memory at the cost of optimal traffic flows; management is OK with this approach given we provide some v4/v6 path independence, if possible. This allows us to manually balance traffic across core links so we can size them appropriately. We still want fast convergence for both IP protocol versions in the core since our SLA offers availability as a refundable parameter if we violate it!

Another really awkward issue is that our Netflow for IPv4 traffic in the core is not being recorded properly. We are seeing zero customer traffic being logged yet all the IPv6 traffic is seen. We think this is related to router performance issues but we can't be certain since it appears consistently broken. We use Netflow as a capacity planning tool for sizing our P-P router links, so ...

8. Given the performance issues, how would you minimize the effect of network failures on business operations while satisfying as many of the requirement as possible? Choose one.
- a. Use MPLS to transport all IPv4/v6 traffic + deploy FRR techniques
 - b. Migrate to single-protocol OSPFv3 to carry both IPv4 and IPv6 AFIs for fast convergence
 - c. Use single-topology ISIS with tuned down timers to affect both AFIs
 - d. Tune down both IPv4/v6 timers and scale up the router hardware to compensate
 - e. Use multi-topology ISIS, tune up IPv4 timers + deploy IP-FRR, tune down IPv6 timers

9. Regarding the lack of IPv4 Netflow data being collected in the core, how can this issue be resolved rapidly? Choose one.
- a. Enable Netflow for MPLS in the core (P ingress)
 - b. Enable Netflow for IPv4 at the edge (PE ingress)
 - c. Change the loopback netmasks on the edge routers
 - d. Change the LDP label allocation filters for the edge router loopbacks
 - e. Redistribute edge router loopbacks into IGP and use route aggregation

10. Regarding the lack of IPv4 Netflow data being collected in the core, how can this issue be resolved while keeping a consistent MPLS/routing design on all LSRs? Choose one.
- a. Disable and re-enable Netflow for MPLS in the core (P ingress)
 - b. Enable Netflow for IPv4 at the edge (PE ingress)
 - c. Change the loopback netmasks on the edge routers
 - d. Change the LDP label allocation filters for the edge router loopbacks
 - e. Redistribute edge router loopbacks into IGP and use route aggregation

To: Designer

From: Nicky "Buffers" Johnson

Subject: Multicast deployment for IPTV services

Whew! Thanks for your help. We changed the edge router loopbacks to /31 and LDP did not allocate labels, and thus the traffic was forwarded as native IP across the core. Definitely a good fix in the short term, but we will go back and update our label filters later since that's a better long-term solution. We finally have time to fix our IPTV service issues since management believes this will be a sizable revenue stream. As you know, we have struggled with this in the path since we've been using unicast for transport, which wastes our bandwidth. Our upstream peers from ISP1 and ISP2 are going to send us multicast flows since we don't have any links to dedicated CDNs (and we certainly don't have our own multicast media being developed in house). The upstreams will be sending us traffic on groups 232.19.85.0/24, using all 256 groups in that range. This is nice from a business perspective since its about 3 times more channels than we used to offer. They didn't really give us more details than this, so we quickly programmed all the customer set-tops with these groups, each of which is mapped to a TV channel. When a customer watches a channel, the set-top signals its interest in a given group to our Internet edge PE and we are expected to deliver the content. Problem is that our management is telling them we have "five nines" of uptime for this entertainment service, which our competitors do not offer. It is preferable to have a way to provide HA in a way that doesn't waste capacity on our core links. Admission control is nice to have, too, and we really don't want to bloat BGP to create these delivery trees using whatever black-magic AFIs exist there. Re-using existing infrastructure is always a plus since it means less stuff to manage and keeps the core simple. At some point those suit-and-tie people are going to tell us to provide IPv6 television services as well (V6-ready has become a pretty obnoxious buzzword around here). PS: you can probably tell me enter key broke again. Someone is playing a trick on me!

11. Fill out the table regarding multicast capabilities as they relate to the core transport requirements. Use an "X" to indicate that a technology offers the specified capability.

	PIM SSM	mLDP in-band	RSVP P2MP TE	Ingress Replication (IR)
Admission control			X	X
BW-efficient FRR		X	X	
BW-efficient general protocol operation	X	X	X	
Low OPEX		X		X
Doesn't need BGP for dynamic discovery	X	X		
Doesn't need multiple protocols for IPv4 + IPv6		X	X	X

12. Given your answers from the previous question, which multicast delivery method do you choose?

- a. PIM SSM
- b. mLDP in-band**
- c. RSVP P2MP TE
- d. Ingress Replication (IR)

To: Designer

From: Nicky "Buffers" Johnson

Subject: Multicast FRR

Hey,

Using mLDP in-band signaling sounds like a good solution for us. I think the #1 driver was the fact that we didn't need to introduce new protocols into the network and have a common way to transport IPv4 and IPv6 multicast without any flavors of PIM in the core. This is a great way for us to save OPEX and we are looking to keep the complexity low which, in turns, drives cost savings.

We will be deploying this, but are still unsure about how to best protect the multicast flows. There are so many options for FRR and I feel overwhelmed in choosing a suitable one to support these hop-by-hop mLDP LSPs. I asked management about exactly what needs to be protected and in which priority order (link, node, SRLG, etc) and they stared at me. The answer is "protect as much as you can". Can you help?

13. Given the requirements and topology, which TE-FRR strategy is best suited for this customer?

Choose one.

- a. One-hop primary tunnels + automatic NHOP backups
- b. One-hop primary tunnels + automatic NNHOP backups
- c. Edge TE mesh between relevant LERs + NHOP backups
- d. Edge TE mesh between relevant LERs + NNHOP backups
- e. Core TE mesh between relevant LSRs + NHOP backups
- f. Core TE mesh between relevant LSRs + NNHOP backups

To: Designer

From: Nicky "Buffers" Johnson

Subject: !!!!!!!!!!!!!!!!

Wow!

This FRR design is smokin' hot. Simple, scalable, and it just works. We haven't missed our availability SLA yet and the company has seen substantial growth in our IPTV service delivery division. We can protect all the links in the core network without needing to think about it; this is pretty important to us and was instrumental in helping us meet our SLA commitments. Management is really happy that we are able to protect the links to the VPN RRs to ensure BGP messaging is minimally affected during failure conditions; this has had a positive impact on our unicast VPN BGP convergence which, by transitivity, positively affects our bottom-line. It is definitely a nice side-effect that we didn't consider but are grateful to have. It helps us keep OPEX down since we can still rely on basic IS-IS for routing.

Anyway, we changed the internet edge router loopbacks back to /32 because we decided to remove Netflow from the core for capacity planning and instead configure it on the ingress PEs per customer, which helps simplify our core network. All IPv4 internet traffic is tunneled inside MPLS again, which is ironic since this is one of the problems we hired you to solve last month. We are debating whether to remove IPv6 from the core ... at this point, we just need to protect our customer's IPv6 internet traffic from any link failure. It looks like the P routers support IPv6 LFA for IS-IS.

14. Given the requirements, which additional technique would you deploy to ensure IPv6 traffic transiting the core is protected from link failures? Choose one.
- a. LFA for IPv6
 - b. LFA + rLFA for IPv6
 - c. 6rd with redundant border relays
 - d. 6PE between LERs
 - e. MAP-E with second-tier MAP-T

15. Arrange the 6PE migration steps in the proper sequence given the business and technical requirements. You may assume that the IPv6 aggregates originated into IGP are the same prefix-length as the iBGP routes advertised from E1/2 to the PEs. (d,c,f,e,b,a)
- a. Disable IPv6 unicast routing on P routers
 - b. Deactivate BGP IPv6 on P routers
 - c. Configure IPv6 unicast BGP+label between E1/2 and PEs
 - d. Configure IPv6 unicast BGP+label between E1 and E2
 - e. Simulate core failures to ensure FRR is functional
 - f. Increase IS-IS IPv6 administrative distance

16. In general, how could you ensure that the VPNv4/v6 RRs are not in the forwarding path for production traffic flows? Choose four.
- a. Use IS-IS stubby area on the P routers facing the VPNv4/v6 RRs
 - b. Set IS-IS overload-bit on the VPNv4/v6 RRs
 - c. Set IS-IS attached-bit on the P routers facing the VPNv4/v6 RRs
 - d. Set IS-IS partition-bit on the VPNv4/v6 RRs
 - e. Utilize IS-IS metric adjustment; maximum-metric on RR-to-P links
 - f. MPLS TE explicit-paths to exclude the VPNv4/v6 RR TE-IDs
 - g. MPLS TE dynamic-paths + link coloring to exclude the VPNv4/v6 RR uplinks

17. Given the requirements, how would you ensure that the VPNv4/v6 RRs are not in the forwarding path for production traffic flows? Choose one.
- a. Use IS-IS stubby area on the P routers facing the VPNv4/v6 RRs
 - b. Set IS-IS overload-bit on the VPNv4/v6 RRs**
 - c. Set IS-IS attached-bit on the P routers facing the VPNv4/v6 RRs
 - d. Set IS-IS partition-bit on the VPNv4/v6 RRs
 - e. Utilize IS-IS metric adjustment; maximum-metric on RR-to-P links
 - f. MPLS TE explicit-paths to exclude the VPNv4/v6 RR TE-IDs
 - g. MPLS TE dynamic-paths + link coloring to exclude the VPNv4/v6 RR uplinks

To: Designer

From: Nicky "Buffers" Johnson

Subject: sorry 4 bad spelling

On my smartphone trying to pick up lunch, but mgmt has been buzzing me all day. After the 6PE migration's success, mgmt wants to know how we can provide basic Internet browsing IPv6 service to our DSL customers using PA addressing. Sorry I don't have a diagram, but just look at the basic diagram to envision our legacy DSLAMs on the PE-CE link. They support BGP-IPv4 and the DSL PE can learn address pools from DSLAM in this way. The CPE routers are new and support stateless 6in4 tunneling & stateless 6to4 translation techniques. Help!

18. Given the requirements, what is the simplest way to provide the required IPv6 services to DSL customers? Choose one technique and one pair of endpoints to construct your solution.
- a. 6PE + CSC
 - b. Hub/spoke IPv6-in-IPv4
 - c. 6rd tunneling
 - d. 6to4 tunneling
 - e. NAT464
 - f. ... On the CPE and DSLAM
 - g. ... On the CPE and DSL PE
 - h. ... On the DSL PE and DSLAM
 - i. ... On the CPE and E1/2 routers
 - j. ... On the DSL PE and E1/2 routers

To: Designer

From: Nicky "Buffers" Johnson

Subject: Not again!

Oh boy! Another issue, this one is important. A NOC engineer thought we needed to configure customer VRFs on the RRs so that they would retain the route-targets. Don't worry, we already fired him, he is cleaning out his desk now. We can't really remove all those VRFs until the next maintenance window but the RRs are virtual boxes and don't have the FIB capacity for this kind of route explosion. Need something fast! We can make configuration changes, just not VRF removal or VPN membership modification.

19. Given the needs of the business, how will you address the FIB scaling problems on the VPNv4/v6 RRs to remedy this issue? Choose one.
- a. Perform aggregation on the PEs of customer routes to compensate
 - b. Increase administrative distance to remove routes from VRF routing table**
 - c. Scale out RRs (quantity-wise) and deploy route-target load-splitting
 - d. Set the IS-IS overload bit to keep the RRs out of the MPLS transit path
 - e. Disable the forwarding table process entirely on the RRs

To: Designer

From: Nicky "Buffers" Johnson

Subject: DCI across (13) layer-3 DCs

Hey,

As you know, our LSN logs have been piling up in our "landfill" datacenters across Europe for years. Now that we've no need for LSN, we still need to retain some of the logs until their 18 month expiry date. The problem is that we don't know where the logs are since once the logs were written to the active DC, they were manually copied to disk and truck-rolled to cold DCs for storage. We've purchased a log consolidation application, hosted in our active DC, which is multi-tiered. The DB and application servers exist only in the local DC, but the top tier is not a web tier, but is a discovery tier. These are sensors have two interfaces. They discover each other using Appletalk SMRP and each DC needs to have one such sensor (a discovery endpoint, in fact). Once the discovery endpoints find one another, they establish TCP sessions back to the application server in client/server fashion over a second NIC. This TCP session is used as a control channel and also for the uploading of logs for consolidation. The TCP session can be either IPv4 or IPv6, and sometimes both, as this gives some layer-3 resilience to the application in case one protocol stack has some internal failure. There are independent DHCPv4/v6 servers in each DC that hand out addresses to servers, and this discovery endpoint is no exception. The application server then compresses all the logs and writes them to disk. This application is awesome because it is smart enough to only backhaul logs that need to be retained; logs older than 18 months are not transferred as it wastes bandwidth.

The idea is that we will develop an architecture to support this application, then decommission all "landfill" DCs since this is a one-time thing. Keeping these DCs isolated from our main DC is critical and we've used different IGPs in each for that reason. I can't wait to be NAT-free! I never thought we would have so much junk to clean up after the fact.

Oh, I almost forgot to attach this diagram. All DCs are connected by dual E-LANs offered by two separate carriers for resilience. Seems ridiculous that we paid all this money just to backhaul logs, but it's actually cheaper to lease these private WANs and digitally move the data than to truck roll across Europe! We are trying to get this cleaned up fast.

We are looking for a solution that gives us policy control over which E-LAN instance to traverse to reach a given DC while at the same time being scalable/fast to deploy. We also have a security requirement to deploy one sensor per rack, and these sensors should not be able to communicate laterally as it could introduce a regulatory issue. Last by not least, upper management is considering leaving the DCs in place after the logs are removed so that we can slowly move into the cloud service provider space. Not sure if you can help with that.

I've attached a diagram (on the next page) for you.

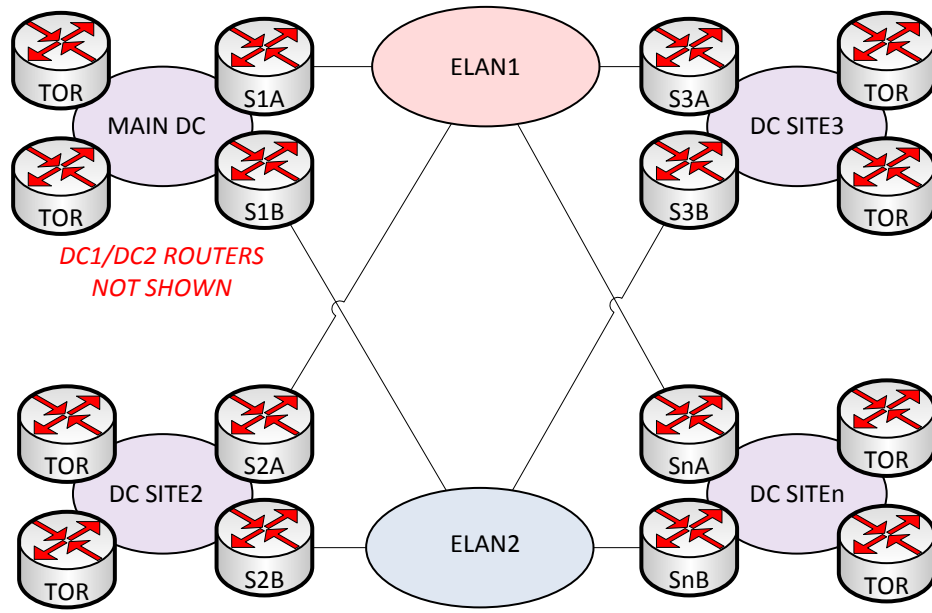

20. Given the requirements, which high-level solution components are most appropriate for LMNOP's DCI solution?
- a. OSPF area 0 over the E-LAN instances with separate areas in each DC
 - b. Migration to ISIS, with L2 over the E-LAN instances and separate L1s in each DC
 - c. Single area OSPF across all DCs
 - d. Single ISIS L2 across all DCs
 - e. Separate IGPs per DC with multiple BGP AS (eBGP) to exchange inter-DC routes
 - f. Separate IGPs per DC with single BGP AS (iBGP) to exchange inter-DC routes

21. Given the requirements, how would you connect the endpoints back to the application server?

Assemble your solution by choosing 2 options.

- a. Single VXLAN L2VPN to carry Appletalk and IP traffic
- b. Appletalk native routing for discovery and IP native routing side by side
- c. **Inter-AS MPLS**
- d. BGP route-reflectors deployed at main DC for scale between sites
- e. **BGP route-servers deployed at main DC for scale between sites**
- f. Full-mesh BGP between all sites to support resilience + path selection

To: Designer

From: Nicky "Buffers" Johnson

Subject: Next Steps

Thanks for your help so far. As I mentioned earlier, we need some kind of resilient and scalable design here. Upper management has decided that once this application scrubs the LSN logs, we need to deliver a flexible inter-DC network where we can provision services on the fly, ultimately enhancing our cloud offerings. We also want to do it securely, if possible. Management thinks that we can tout our end-to-end service offerings to attract new business. Using similar network techniques for multi-tenancy that we use in the carrier space would help us control costs for our cloud offerings, too. Apparently we aren't going to scrap these other DCs, we are going to try and turn them into new profit centers.

Oh, and the cost of router memory hasn't gotten cheaper. Any new routers you deploy need to be bare-bones on DRAM! E-LAN2 carrier also increased their prices, so we've reduced the bandwidth on that connection. Ideally the solution will allow us to do some path manipulation so that we can prefer ELAN1 over ELAN2.

22. Drag and drop icons, then interconnect those items using links/sessions in order to complete the design. The quantities of each item are shown below; if an item does not specify a quantity, it is unlimited. The blue dotted circles represent potential device locations. Note that the two circles in the center of the diagram are physically located in the main DC and are connected directly to the ELAN networks as specified in the diagram.

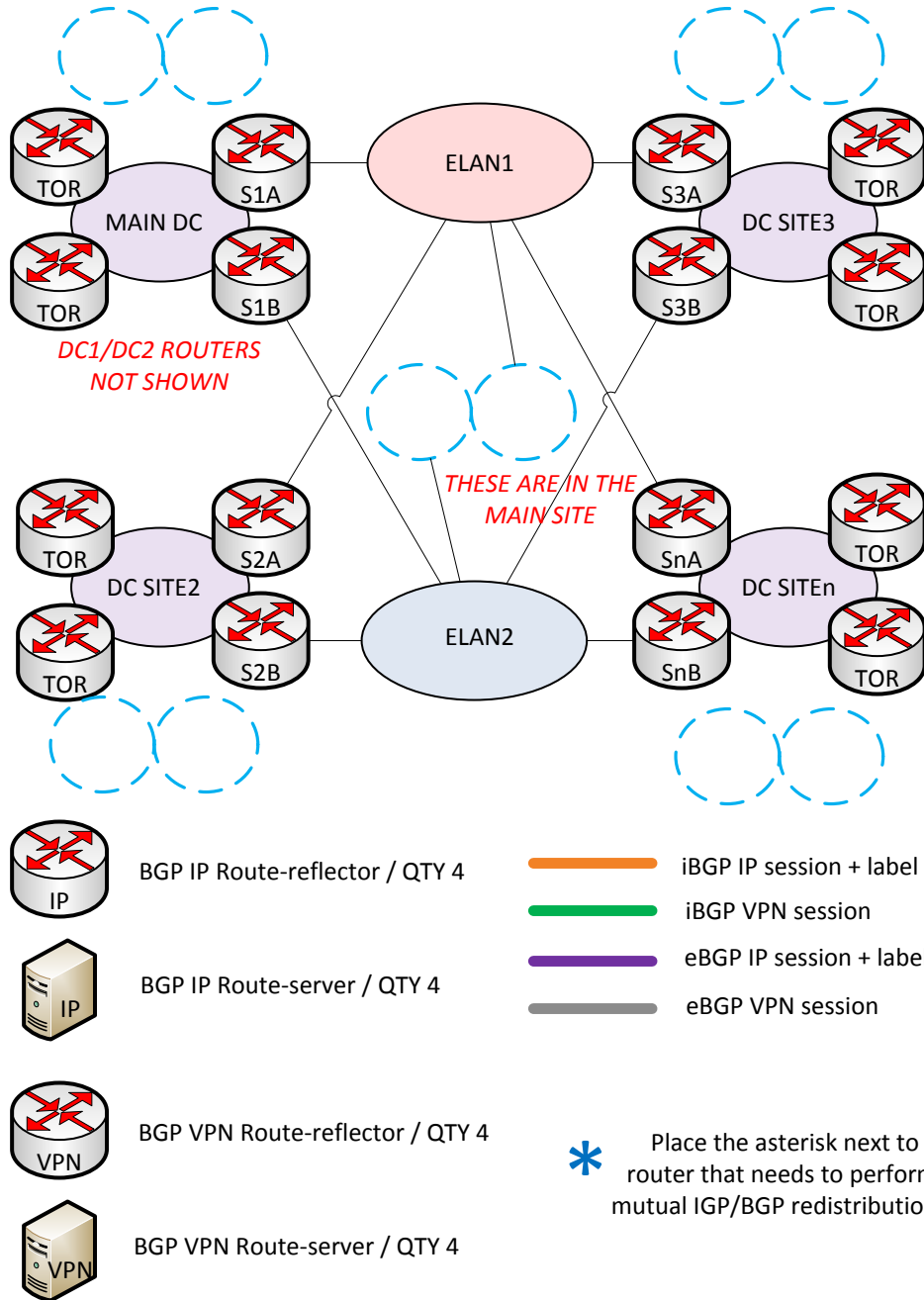

Note that different shades of purple/gray are used just for clarity in the diagrams.

Correct answers:

Option C + route-server + iBGP to TOR (SITE2 only for example)

Option C + route-server + redistribution (all other sites)

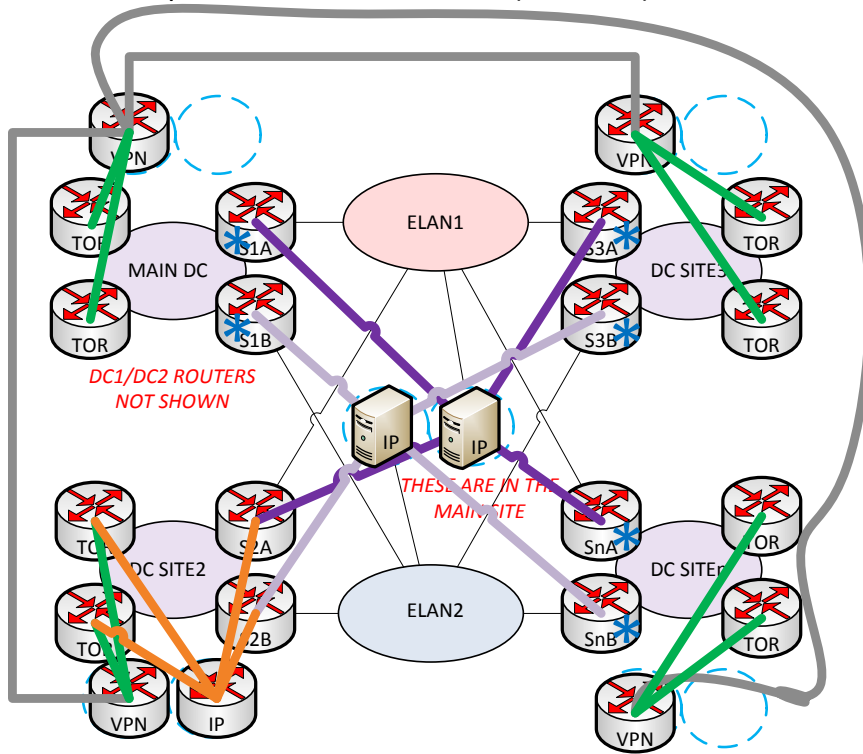

000

Less points answer – Option B + route-server

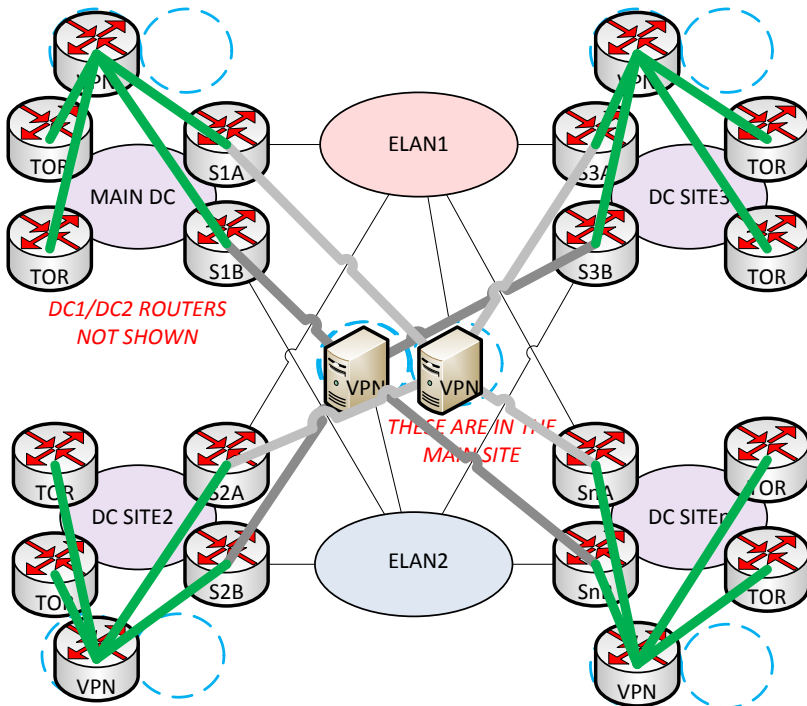

To: Designer

From: Nicky "Buffers" Johnson

Subject: Not so fast!

I spoke too soon in saying we were "done" with LSN technologies. We gave our customers plenty of warning that we were going to become an IPv6-only ISP, but you know how that goes. We already disabled LSN on our E1/E2 routers and sold the hardware cards on the gray market for some extra money, so going back to LSN would be costly for us. I think we are just going to re-enable IPv4 transport in our network since we can issue public IPv4 addressing to the CPEs now; let them do NAT44 one time and we don't have to worry about HSL and all the headaches associated with it.

As you may know, we allow our customers to multi-home to us, both for IP and VPN services. One particularly large Internet of Things (IoT) customer, NuBrush, creates smart toothbrushes that monitor the temperature of one's mouth while brushing. If the temperature is outside of a normal threshold, typically one standard deviation from the normal human mouth temperature (98.6F / 37C), it will send an SNMP trap back to a set of centralized servers at their headquarters building. I'm not sure why anyone would ever buy such a thing ...

I wouldn't be telling you all that unless it mattered. The customer has many sensor servers spread throughout Western Europe and the sites that house these collection devices connect to our network. We provide a private WAN service over MPLS for them. They use IPv6 for this since they have already sold millions of toothbrushes at very expensive prices, so they are growing fast. The toothbrushes are LTE-enabled and the collection sites receive updates from the toothbrushes through an LTE carrier; those guys must be rich now.

NuBrush is connected to our network as shown below. Their primary circuit is a 40Gbps Ethernet circuit over fiber while the backup is an STM-64 leased line from a transport provider; this is true for the HQ only. All other sites where collection sensors exist are single-homed. We are seeing all SNMP traps being sent to the HQ site over the STM-64 and not the 40 Gbps link. We thought BGP was smart enough to figure this out on its own?

We need a solution that, at a minimum, sends more traffic over the primary link versus the backup link. I would prefer that you can find a way to load-share in proportional manner but I know this will be more complex. Keeping complexity to a minimum is very important to reduce OPEX, but also consider optimal forwarding since that also saves OPEX. Low-impact is always better. Make some recommendations and I'll decide.

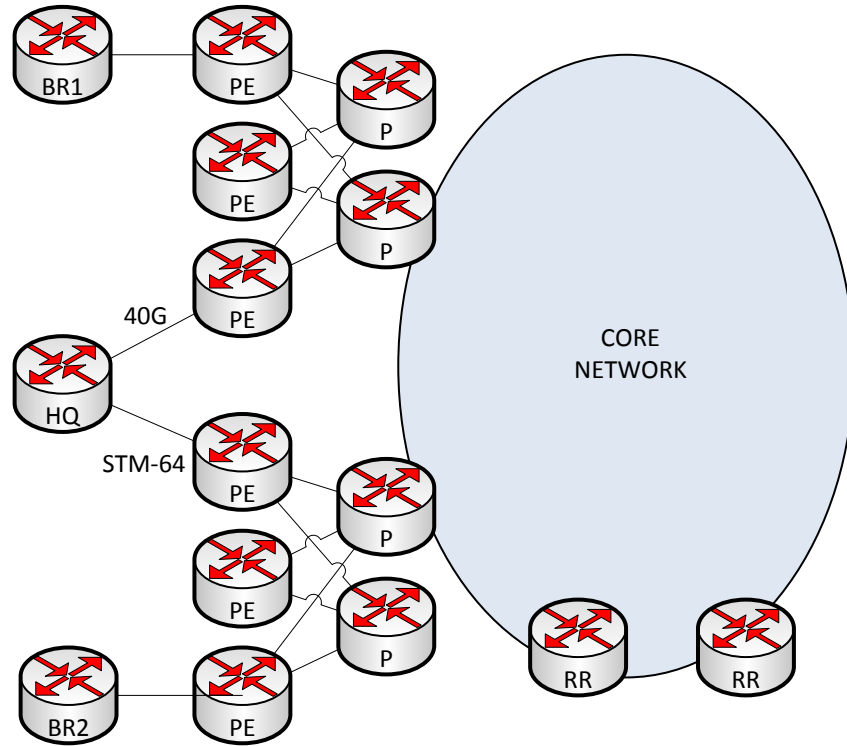

23. Given the requirements, how would you design a BGP solution to resolve this issue? Assemble your solution by choosing 2 options.
- a. BGP additional-paths for VPNv6 only
 - b. Unique RD per NuBrush HQ VRF
 - c. Unique RD per NuBrush HQ and remote site VRFs
 - d. BGP link-bandwidth community at the NuBrush HQ VRFs
 - e. BGP link-bandwidth community at the NuBrush HQ and remote site VRFs
 - f. High BGP local-preference on primary circuit + best-external on the backup circuit at the NuBrush HQ VRFs

24. LMNOP has ruled out using BGP additional-paths and will not change RDs at the remote sites. Continue your story from the previous question by developing a design that best meets NuBrush and LMNOP requirements.

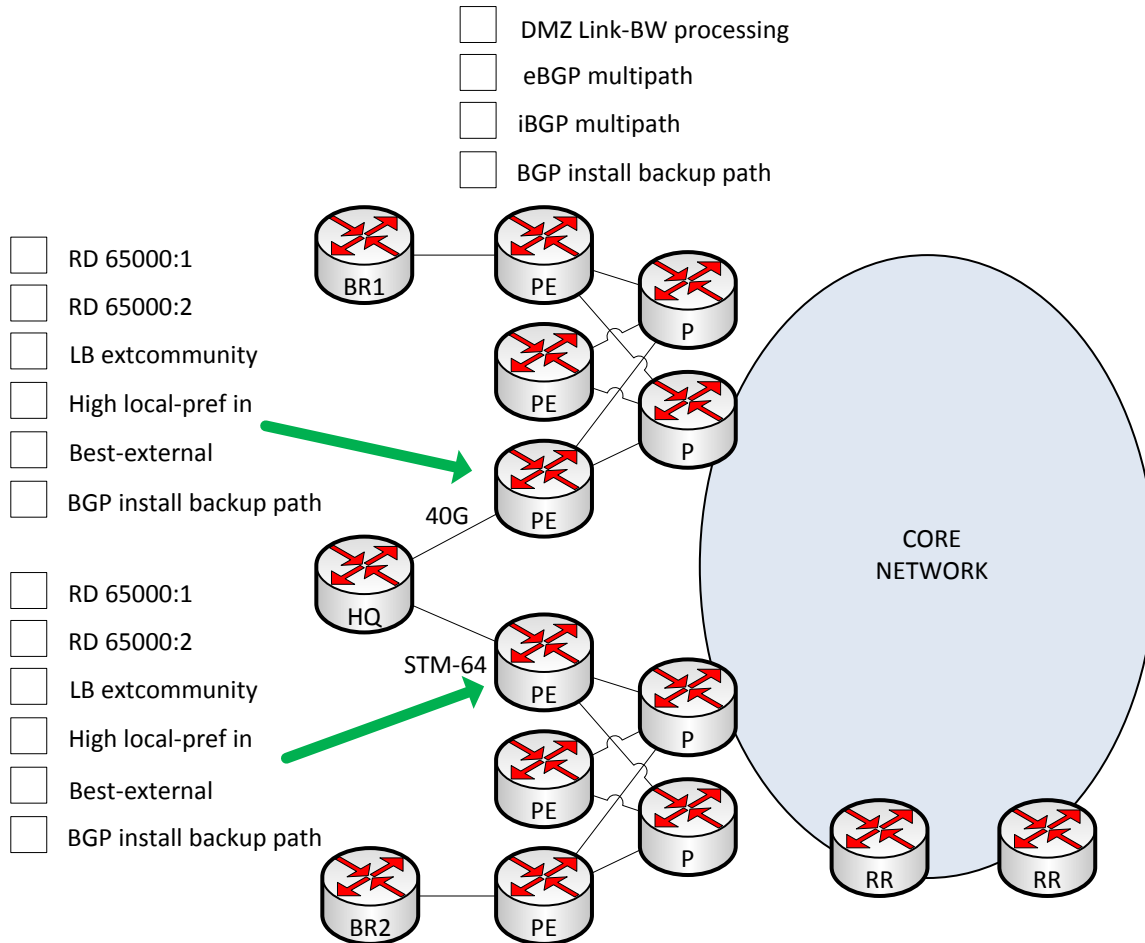

**Correct answer 1:
DMZ link-BW unequal-cost load sharing
in an active/active design**

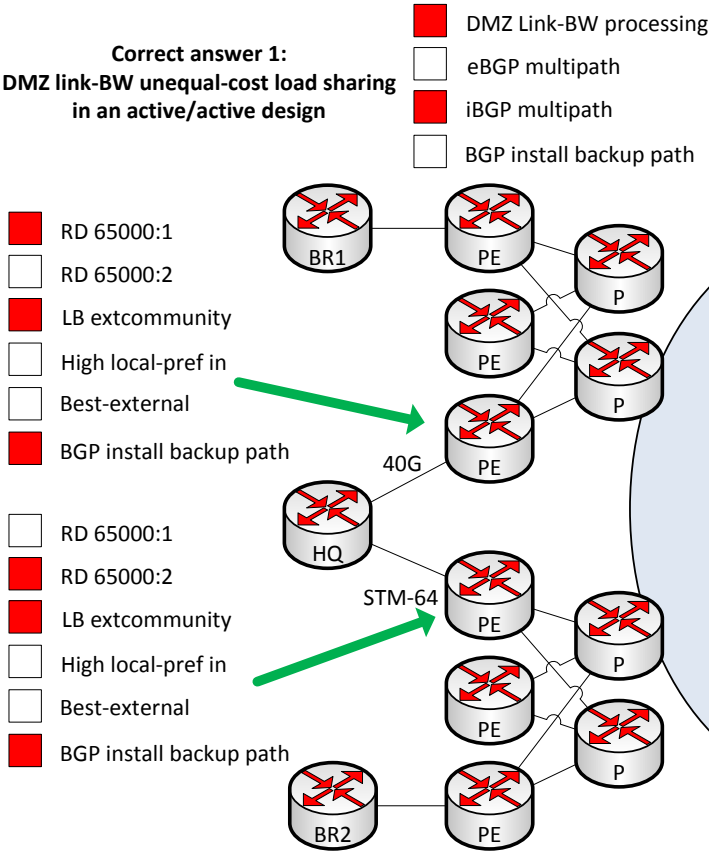

**Correct answer 2:
BGP best-external with local-pref
in an active/standby design**

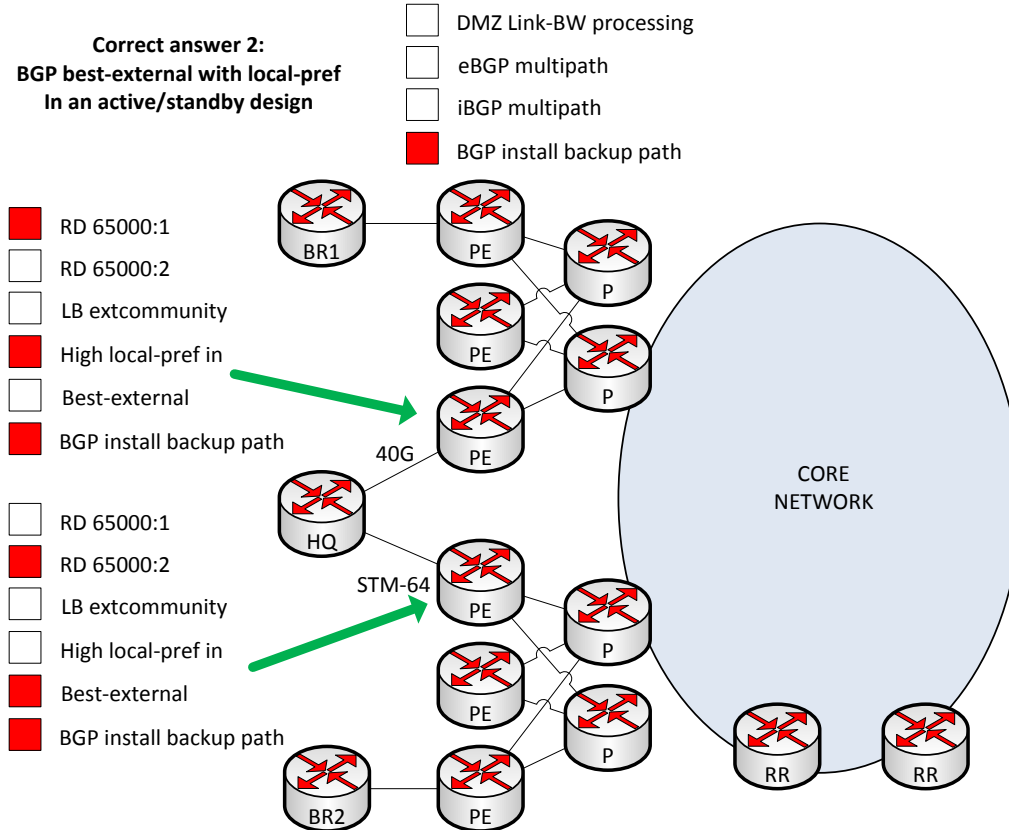

To: Designer

From: Nicky "Buffers" Johnson

Subject: Convergence issue

No time to waste on niceties here, we have a serious problem. We decided to go with the active/standby solution using local-preference and best-external since we felt it was simpler, and not using the STM-64 isn't that big of a deal. Maybe a waste of money for us (and them) but now we don't have to mess with fancy load-sharing.

From a logical perspective, we have point-to-point circuits from our PEs to NuBrush HQ yet convergence is very slow. During a recent construction project in Caen (NW France), the primary circuit was damaged and several minutes' worth of critical temperature measurement data was lost!!! Hopefully you can see my sarcasm, but they are our customer at the end of the day. We (and the customer) expected very fast convergence when the link was cut but it didn't quite work out. All of the remote office PEs had their BGP backup paths properly installed; I personally checked that myself.

Failover to the backup circuit did eventually work as expected but the customer is operating at a degraded capacity while the link is repaired. We want to ensure this doesn't happen again, but we aren't really worried about the degraded capacity on the backup link in the short term. That is what happens when you buy a slow backup link. I have another meeting with management, likely to be lambasted for this.

PS: We thought about enabling BFD but had some doubts, since the link appears to be point-to-point and both the PE and CE don't support processing BFD control packets in hardware. I don't usually get involved with layer-1 stuff but here is the detailed access network diagram.

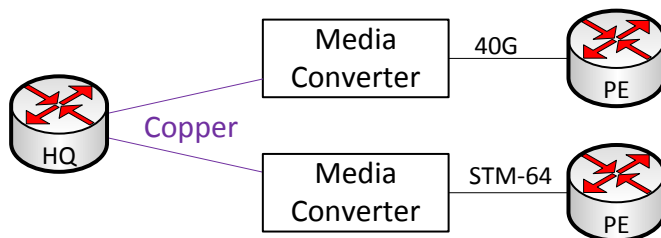

25. What technology would you introduce to resolve the current issue? Choose two answers to construct your overall solution.

- a. BGP keepalive tuning
- b. BGP fast external fall-over
- c. BFD echo mode
- d. BFD asynchronous mode
- e. BFD demand mode
- f. ... On both ends of the STM-64 link
- g. ... On both ends of the 40 Gbps link
- h. ... On the HQ router
- i. ... On the PE router